

# IN-LINE SYSTEMS

No other company in the world can match our experience in designing Inverters to work as part of an integrated in-line operation.

Most of the machines in our range lend themselves to conveyor-fed operation in one form or another. Here we explain how they work.

If you are involved in an operation where you believe a continuous conveyor-fed system could be justified our experience is at your disposal. After studying your project in detail we will recommend the appropriate machine and quote accordingly.



## IN-LINE RR

The in-line RR is probably the most versatile system as it can cater for both wide and heavy loads, with the extra benefit of allowing stacks which don't need inversion to pass straight through.

- 1 The load enters from one side
- 2 The stack is clamped and reclines through 90°
- 3 It revolves 180°
- 4 The load returns to the line
- 5 As one load exists the next one can enter

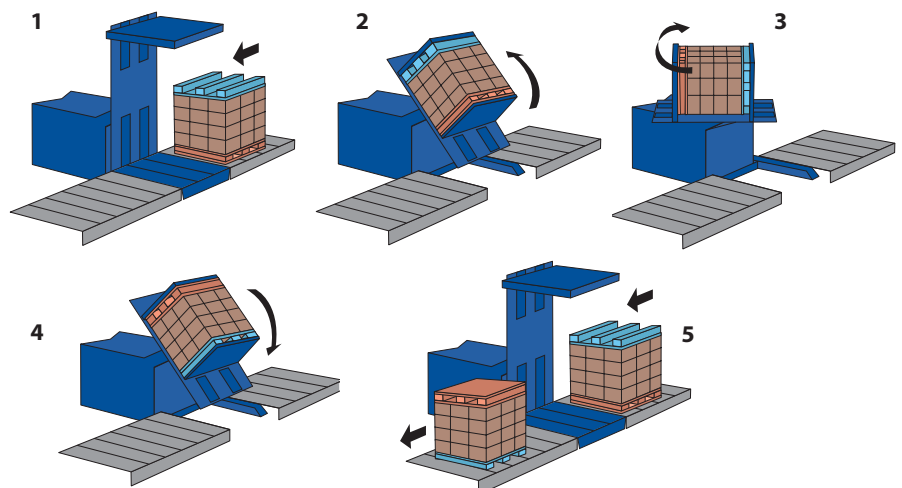

The RR can also be sited 'off-line'. The picture to the left shows how loads of boards which need turning can leave the main conveyor route, enter the RR and then return to it after inversion.

# IN-LINE SYSTEMS

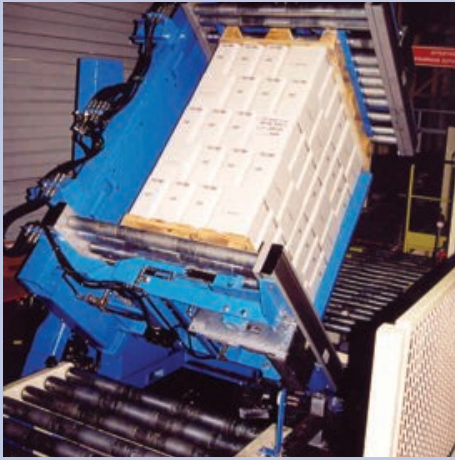

## IN-LINE FS DC

The FSDC is the most economic in-line system in terms of both space and price. Loads enter to one side travelling up the fixed wall before stopping. This ensures the goods are fully supported during inversion.

The system pictured here features pallet grippers which put a new pallet on top of the stack and recover the old one after inversion. The sidewall can be programmed to open allowing loads to pass through when necessary. This also means that in high throughput situations the machine does not need to re-invert to receive the next pallet load.

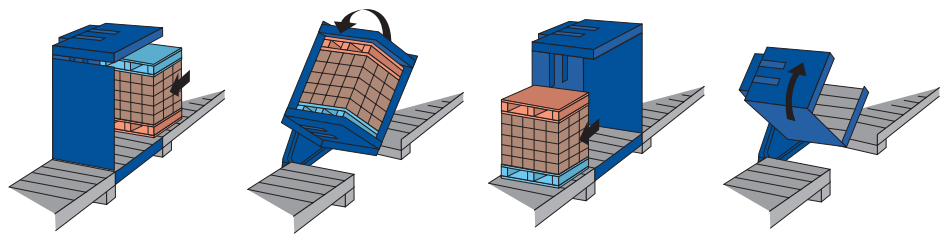

## IN-LINE PALLET CHANGER

The Pallet Changer works "off-line" allowing goods which do not need transfer to pass straight by. Its principal benefit is to return goods to their original upright position on a new pallet so it is ideal for product which cannot remain inverted.

The load reclines back, supported on the top and sides while the pallet returns to conveyor level for exchange. This style of operation means it is best suited to block stacked goods such as boxes or cluster-packs but less well for sacks or product in thin layers such as cardboard sheet.

