



materials handling

Data Sheet

FS DC INVERTER

The FS DC is the most adaptable inverter on the market and can be loaded either at floor level or by FLT. The standard model can handle loads from 2m down to 640mm height. It can be set up to load by FLT or adjusted to open the tables to ground level for pallet truck access over a short ramp. We can swap the tables to provide floor-flush loading by hand pallet truck if required.

The FS DC is supplied with attached guards as standard and we can fit a single safety photobeam between the feet. If floor fixed guards are required we can supply a multi-beam photo-electric guarding system.

Custom built machines available - maximum load parameters are 2400mm wide, 2500mm high and 3 tonnes in weight.



USES INCLUDE

- Load transfer from wood to plastic or other hygienic pallet
- Recovery of damaged bags or broken boards from bottom of the stack
- Switching to/from high quality in-house pallets
- Recover used freezer spacers from stacks of frozen foods

KEY FEATURES

- 180 degree free standing inverter
- Loading capacity 2000 kgs
- Twin chain-linked clamping tables
- Relocatable by forklift truck
- Adaptable – can be loaded at floor level or by forklift truck
- Ideal for in-line conveyor-fed applications
- Push button controls
- Excellent range of clamp travel
 - perfect when a wide variety of loads need to be handled.

The FS DC in operation

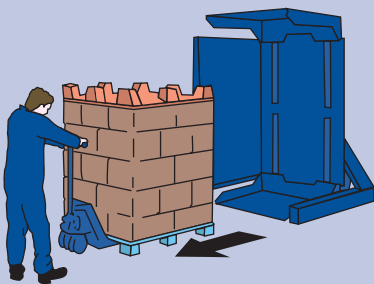
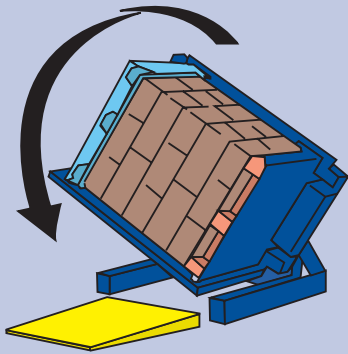
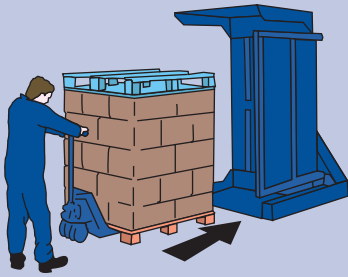

FS DC INVERTER

Specifications

Usable Jaw Opening	Ramp Loaded Tables: 2.00m max 0.64m min Floor Flush Tables: 2.00m max 0.74m min
--------------------	------------------------------------------------------------------------------------

Increased jaw opening models also available

Standard Load Tables	Ramp Loaded Tables: Width 1.30m Depth 1.30m Floor Flush Tables: Width 1.40m Depth 1.30m
----------------------	--------------------------------------------------------------------------------------------

Normally supplied with 1.20m long loading ramp

Loading Capacity	2000 kgs
------------------	----------

Power Supply	3ph / 400V / 20A
--------------	------------------

Motor Size	4.0kW
------------	-------

Weight	2255 kgs
--------	----------

Weight of Guards	175 kgs
------------------	---------

Controls	Extended individual push button controls with semi or fully auto-sequenced systems available as an option
----------	--------------------------------------------------------------------------------------------------------------

Operating Space (including attached guards)	A Width 2.80m
	B Depth 2.30m
	C Height 2.48m

Depth increases to 3.31m when fitted with floor fixed guards and multi photo-beams

Standard Shipping Dimensions (with guards fitted)	Width 2.80m Depth 2.30m Height 2.20m
------------------------------------------------------	--------------------------------------------

SIDE ELEVATION

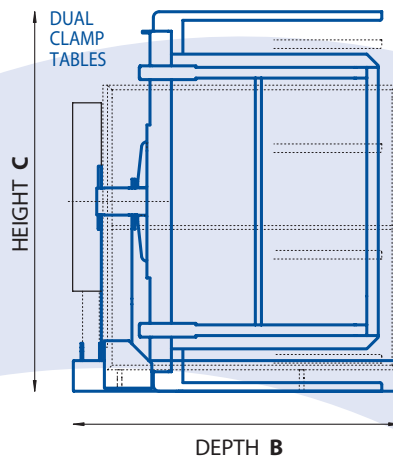

PLAN VIEW

