

RR TYPE 2 INVERTER

The RR Type 2 is a lightweight 180° Inverter with twin clamp tables which open flush-to-floor level.

It has a maximum loading capacity of 1000kgs.

It is stable by design and can be easily relocated by forklift truck but would be secured to the floor during normal operation.

The RR Type 2 is designed for low volume applications where floor level loading is essential and operating space is at a premium.

Although it can be modified to some extent, it is normally used with pallets up to 1200mm x 1000mm and loads of under 1400mm in height.



USES INCLUDE

- Inversion of paper stacks for reverse side printing
- Recovery of broken pallets or damage at the bottom of the stack
- Simple pallet-to-pallet transfer of smaller loads in a confined workplace

KEY FEATURES

- 180° inversion with hydraulic clamp and tilt plus manual load turning
- Loading capacity of 1000kgs
- Twin chain-linked clamping tables with variable pressure adjustment
- Dual lever or hydraulic push button controls
- Simple, quick and effective transfer of small, lightweight loads
- Neat construction with enclosed hydraulic powerpack
- Very low maintenance

METHOD OF OPERATION

RR TYPE 2 INVERTER

Specifications

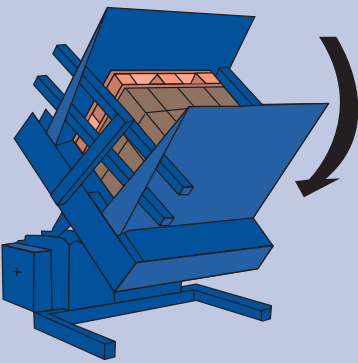
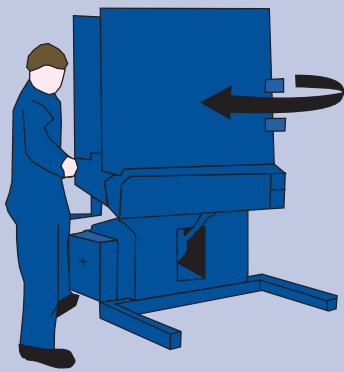
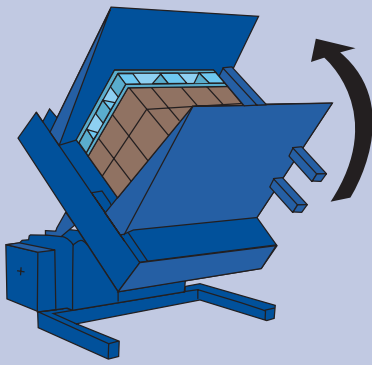

Usable Jaw Opening	Max 1.40m Min 0.39m
Standard Load Tables	Width 1.30m Depth 1.00m
Loading Capacity	1000kgs
Power Supply	3ph / 400V / 15 amp
Motor Size	2.2kW
Weight incl. guards:	1400kgs
Controls	Twin hydraulic levers or optional individual push button controls
Operation space	A Width 1.94m B Depth 2.69m C Height 2.23m
Standard Shipping Dimensions	Width 1.94m Depth 2.69m Height 1.40m

SIDE ELEVATION

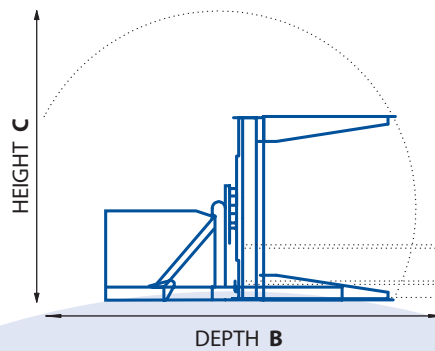

PLAN VIEW

